



Model 948A/AX

Cue Tone Receiver

INSTRUCTION MANUAL

Monroe Electronics
100 Housel Ave | Lyndonville | NY | 14098
800-821-6001 | 585-765-2254 | fax 585-765-9330
monroe-electronics.com

Printed in USA | Copyright© | Monroe Electronics, Inc.
Specifications subject to change without notice

P/N 1340177
9/29/04

TABLE OF CONTENTS

WARRANTY	2
RETURN POLICY	2
GENERAL DESCRIPTION	3
INSTALLATION	4
OPERATION	6
3185E INSTRUCTION MANUAL	8
DESCRIPTION	9
SPECIFICATIONS	10
INSTALLATION	11
Mounting	11
Pin Numbers and Functions	11
FIGURE 1 - <i>Edge Connector, Switch and Indicator Locations</i>	12
FIGURE 2 - <i>Block Diagram</i>	12
Audio Input Connection	13
‘Set’ Input Connection	13
‘Reset’ Input Connection	13
Relay Output Connection	13
Power Supply Input	13
CUSTOMER OPTIONS	14
FIGURE 3 - <i>Jumper Locations</i>	15
Input Impedance	15
Input Balanced/Unbalanced	16
5 Minute Restoral	16
20 Minute Reset	16
Output Relay	16
10 Second Pulse	16
Number of Digits to Decode	17
Fourth Digit ON/OFF	17
CODE SELECTION	18
OPERATION	18
Operating With a 4-Digit Code	18
Operating With a 3-Digit Code	19
Operating With a 2-Digit Code	19
Operating With a 1-Digit Code	19
ADJUSTMENT	19

WARRANTY

Monroe Electronics, Inc. warrants to the owners, each instrument and sub-assembly manufactured by them to be free from defects in material and workmanship for a period of one year after shipment from factory. This warranty is applicable to the original purchaser only.

Liability under this warranty is limited to service, adjustment or replacement of defective parts (other than fuses or batteries) on any instrument or sub-assembly returned to the factory for this purpose, transportation charges prepaid.

This warranty does not apply to instruments or sub-assemblies subjected to abuse, abnormal operating conditions, or unauthorized repair or modification.

Since Monroe Electronics, Inc. has no control over conditions of use, no warranty is made, or implied as to the suitability of our product for the customer's intended use.

THE WARRANTY SET FORTH IN THIS ARTICLE IS EXCLUSIVE AND IN LIEU OF ALL OTHER WARRANTIES AND REPRESENTATIONS, EXPRESS, IMPLIED OR STATUTORY INCLUDING, BUT NOT LIMITED TO THE IMPLIED WARRANTIES OF MERCHANTABILITY AND FITNESS. Except for obligations expressly undertaken by Monroe Electronics, in this warranty, Owner hereby waives and releases all rights, claims and remedies with respect to any and all warranties, express, implied or statutory (including without limitation, the implied warranties of merchantability and fitness), and including but without being limited to any obligation of Monroe Electronics with respect to incidental or consequential damages, or damages for loss of use. No agreement or understanding varying or extending the warranty will be binding upon Monroe Electronics unless in writing signed by a duly authorized representative of Monroe Electronics.

In the event of a breach of the foregoing warranty, the liability of Monroe Electronics shall be limited to repairing or replacing the non-conforming goods and/or defective work, and in accordance with the foregoing, Monroe Electronics shall not be liable for any other damages, either direct or consequential.

RETURN TO FACTORY POLICY:

Materials returned to Monroe must have a Return Material Authorization number. To obtain a RMA number, contact our A/V Switching & Control Customer Service at 585-765-2254 or fax 585-765-9330. Customers have 30 days to determine that the product ordered fills their need and performs as described in Monroe's literature. Units returned for approved repair or credit, must be in the original packaging including all parts and paperwork plus be in very good physical condition. If not, the customer is billed the cost to refurbish the unit and for missing accessories and merchandise. No products may be returned for exchange or credit after 12 months of the shipment date. Monroe reserves the right to repair or replace units under warranty.

GENERAL DESCRIPTION

The Model 948A/AX Cue Tone Receiver is a small wall mounted enclosure containing 2 or 3 PC boards, in plus a power unit. The Model 948A contains a Model 3137B UAD, a Model 3185E Dual Tone Decoder, a Model 3446A Stereo Audio/Video Switch, with a, wall mounted power supply. The Model 948AX contains all the above parts, EXCEPT the Model 3137B UAD.

The units are designed to switch a Stereo Audio-follow-Video or IF/RF signal if the proper DTMF tone sequence is entered. These signals may be received from various audio sources, including satellite audio or microwaves. The Model 948A may also be controlled via a dial up telephone line.

INSTALLATION

1. Remove the two screws holding the cover on the 948A and remove the cover.
2. The Model 3185E is factory set to decode a 4-digit 'ON' code sequence and a 4-digit 'OFF' code sequence. The first three digits in the code sequence are determined by the hexadecimal rotary switches on the front edge of the 3185E. 0 through D select the corresponding DTMF digit to be decoded. The letter 'E' on the rotary switch represents the '*' DTMF digit and the letter 'F' on the rotary switch represents the '#' DTMF digit. The fourth digit for the 'ON' code sequence is factory set to '*', and fourth digit for the 'OFF' code sequence is set to '#'. Set the rotary switches on the 3185E to the Cue Tone sequence you wish to decode. See the 3185E manual for more information.
3. The Cue Tones may be received by the Model 948A from the alternate program source (baseband audio) or other audio subcarriers. If so, connect an audio cable from the Cue Tone source to TB1 #4 with common on TB1 #5 (ground). If installing a 948AX, connect Cue Tone Audio to TB2 #8 and TB1 #5 (ground).
4. Connect the video from the main program source to the normally closed (NC) F connector on the 3446A card.
5. Connect the video from the alternate program source to the normally open (NO) F connector on the 3446A.
6. Connect the modulator video input to the common (COM) F connector on the 3446A card.
7. Connect the Left and Right Audio inputs, and the Audio output, to the screw terminals on the mother board as shown in the accompanying schematic.
8. Connect the White (+12) lead from the power supply to TB1 #7 and the Black (GND) lead from the power supply to TB1 #6.
9. If your model is a 948A, the audio tones may be supplied over the telephone line and/or from an audio source as described above. If the signals come ONLY over the telephone line, disregard item 3 above.
10. Attach the Tip and Ring lines from the POTS line to the connections as shown on the attached drawing.
11. The 3137B is set to answer on 2 rings, and hang up on current disconnect when the calling party hangs up. See the 3137B manual for more information.

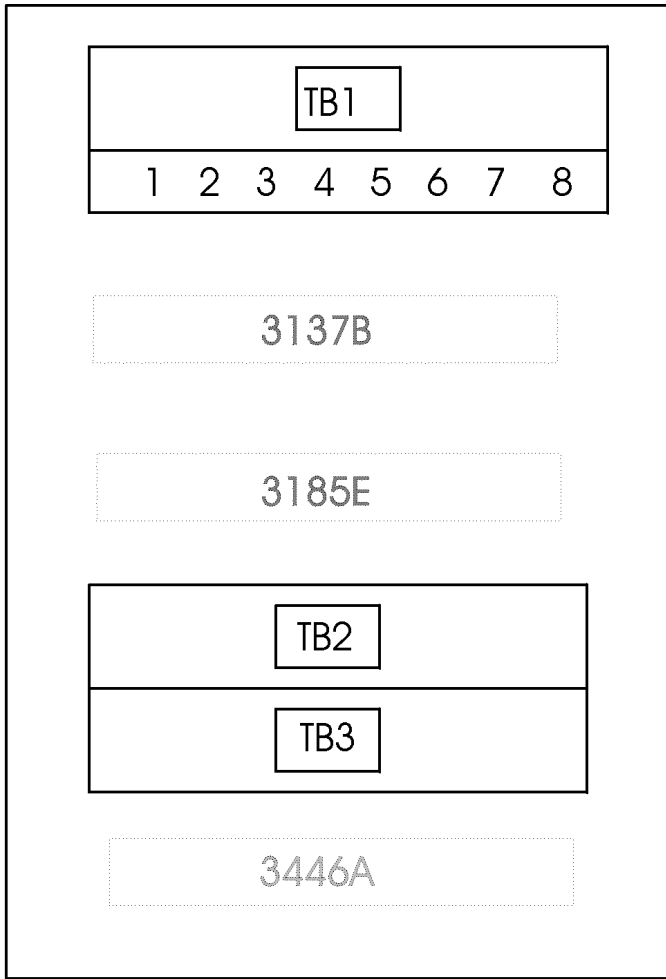

**SCREW TERMINAL SIDE (BACK)
OF INTER-CONNECT PC BOARD.
PLUG IN BOARDS ON OTHER SIDE.**

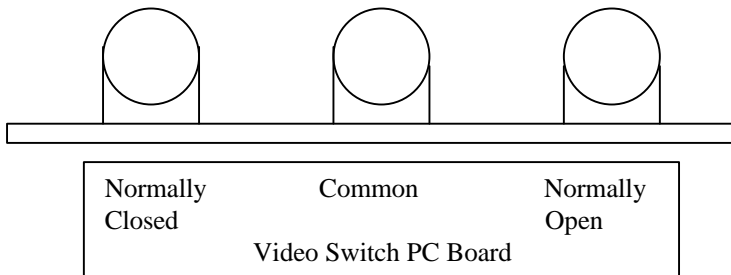

OPERATION

The Model 3185E Dual Tone decoder monitors the audio at TB #1 pin 4 for the specific four digit Cue Tone 'ON' code sequence to which it is programmed to respond. When it receives the correct code, the 3185E's relay energizes, which supplies ground to the 3446A Relay card, energizing it's relays. This switches in the alternate audio/video program source.

The 3185E continues to monitor the audio at TB1 #4 and when it receives the correct 'OFF' code sequence, it de-energizes it's relay and de-energizes the relays on the 3446A card. This returns it back to the main program source.

If the Model 3137B UAD has answered the telephone line, the above connection is isolated, and tones supplied over the telephone line are used – as above – to activate the device.

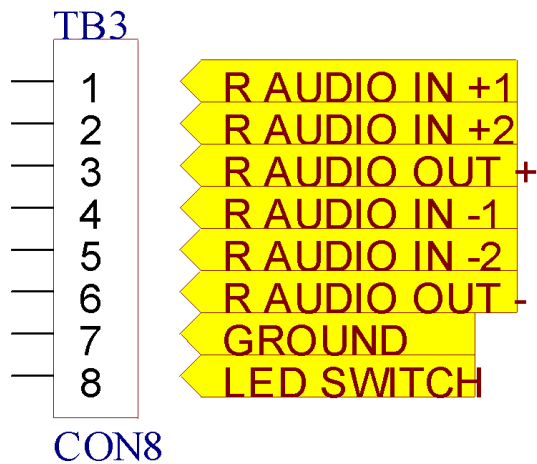



Model 3185E

DUAL TONE DECODER

INSTRUCTION MANUAL

Monroe Electronics
100 House I Ave | Lyndonville | NY | 14098
800-821-6001 | 585-765-2254 | fax 585-765-9330
monroe-electronics.com

Printed in USA | Copyright© | Monroe Electronics, Inc.
Specifications subject to change without notice

P/N 1340163
090104

DESCRIPTION

The Model 3185E Dual Tone Decoder is capable of accepting a sequence of up to four dual tone signal inputs such as those from a Touch-Tone[®] telephone keypad. It provides a relay closure as its output. Standard features include:

- Dual Form C Relay Output
- Selectable Input Impedance
- Selectable Balanced/Unbalanced Input
- Adjustable Input Signal Range
- Restoral of Output Status if Power Interruption is Less Than 5 Minutes.
- Selectable 20 Minute Relay Output Reset
- Digit Sequence Selectable up to Four Digits
- Selectable Relay Output Action (latching, momentary, or alternate).
- Level Sensitive 'Reset' Input
- Level Sensitive 'Set' Input

SPECIFICATIONS

Input Coupling -----	AC
Input Impedance:	
Factory Setting -----	10 k Ω Minimum
Selectable -----	600 Ω Terminated
Input:	
Factory Setting -----	Unbalanced
Selectable -----	Balanced
Common Mode Range -----	\pm 5 Volts
Input Signal Range:	
Minimum -----	50 mV p-p
Maximum -----	1.5 V p-p
Input Range:	
Nominal -----	-14 dBm to -4 dBm (155mV to 489)mV
Optional -----	\pm 10 dBm Adjustable
Digit Validation Time -----	40 ms Minimum
Inter-Digit Time:	
Minimum -----	40 ms
Maximum -----	3 Seconds
Maximum Digits Per Second:	
No Twist -----	13
\pm 6 dB -----	12
Relay Output -----	DPDT 30 VDC @ 2 Amp.
'Reset' Line -----	Level Sensitive Minimum 20 ms Pulse to Ground.
'Set' Line -----	Level Sensitive Minimum 20 ms Pulse to Ground.
Edge Connector -----	Monroe Model 3000RK (Cinch Jones 50-20A-30)
Power Requirements -----	12 Volts D.C. \pm 10% 40 mA Maximum.
Physical Dimensions -----	5.0 in.H x 3.0 in.W x 0.6 in.D

INSTALLATION

Mounting:

The Model 3185E is designed to plug into a Monroe 3000RK 20-pin edge connector. All connections are intended to be made at the edge connector and will be referred to in this manual by edge connector number or letter.

Pin Numbers and Functions:

Pin numbers are listed below for the Model 3185E when plugged into a 3000RK Connector. Consult FIGURE 1 on page 4 for proper registration of pin numbers.

PIN NUMBER	FUNCTION
1	Common terminal for relay output referenced to pins 9 and 10.
2	Circuit common (ground).
3	Circuit common (ground).
5	Audio input low (audio input circuit common if unbalanced).
6	Audio input high.
8	+12 Volt D.C. power supply input.
9	Normally closed contact for relay output referenced to pins 1 and 10.
10	Normally open contact for relay output referenced to pins 1 and 9.
A	Common terminal for relay output referenced to pins K and L.
B	Reserved. Connections to this pin will disable card.
D	'Set' input.
E	'Reset' input.
K	Normally closed contact for relay output referenced to pins A and L.
L	Normally open contact for relay output referenced to pins A and K.

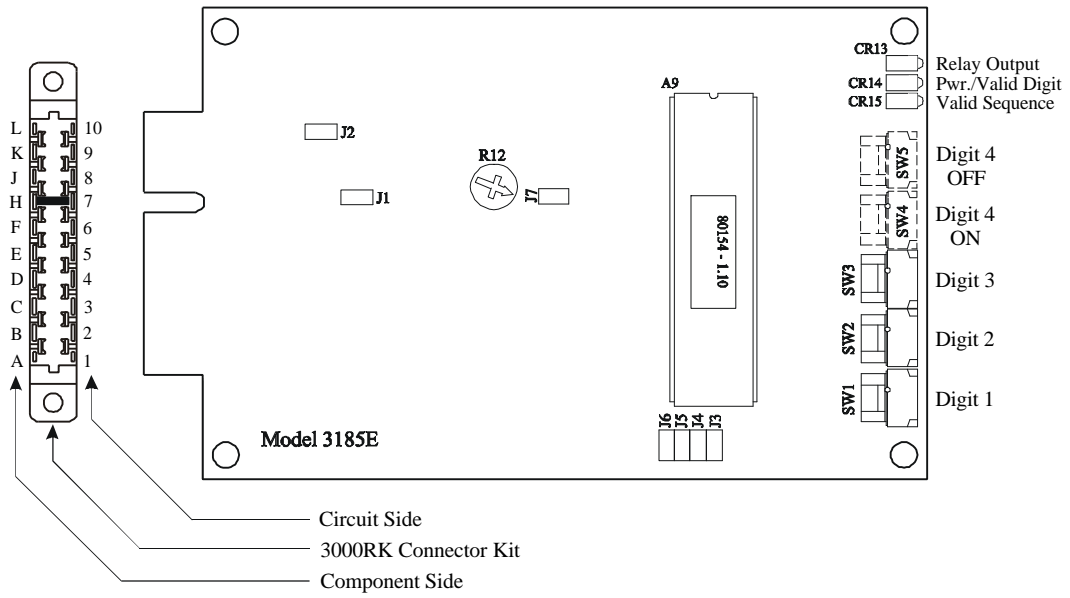

FIGURE 1
Edge Connector, Switch and Indicator Locations

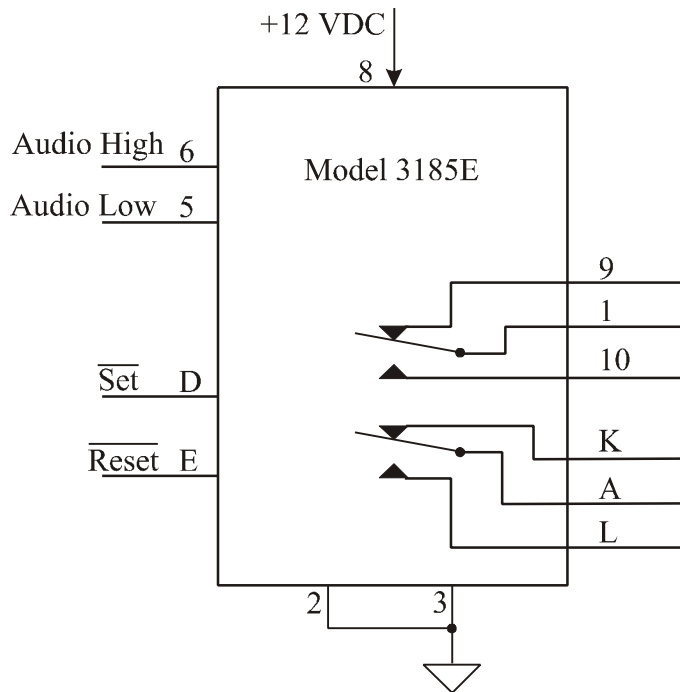

FIGURE 2
Block Diagram

Audio Input Connection:

The audio input is connected at pins '6' and '5' (circuit common). The 3185E is factory set at 10 kΩ input impedance; unbalanced. This audio input may be changed by the customer to have a 600 Ω termination instead of 10 kΩ, and also to be balanced instead of unbalanced. Consult the CUSTOMER OPTION section for more explanation.

'Set' Input Connection:

The 'Set' input is connected at pin 'D', and when pulsed to circuit common will energize the output relay. The output relay will remain energized until the proper 'OFF' code is received or the 'Reset' input is pulsed to ground. This input is level sensitive and requires a minimum pulse width of 20 msec. to circuit common to activate or de-activate the output relay. The 'Set' input has precedence over all functions except 'Reset'.

If the 3185E's 'Set' input is pulsed to circuit common while decoding a code sequence it will clear previous valid digit(s) decoded after the 'Set' input returns to a 'high' state.

'Reset' Input Connection:

Momentarily connecting pin 'E' to circuit common will cause the 3185E to reset. This input is level sensitive and requires a minimum pulse of 20 msec. to circuit common to reset the card. The 'Reset' input dominates over all other functions.

NOTE: The 3185E will ignore all commands or code sequences until the 'Reset' input is removed from circuit common.

Relay Output Connections:

The 3185E provides a dual Form C relay output. The output relay will energize whenever the preprogrammed 'ON' code sequence is received or the 'Set' input is momentarily connected to circuit common. If the output relay is set to 'momentary', the output relay will activate approximately 40ms after the last valid digit is received and stay on as long as the last valid digit is present. If the output relay is set to 'latching', the output relay will remain energized until the programmed 'OFF' code sequence is received or the 'Reset' input is momentarily connected to circuit common.

The dual Form C relay output connections are shown below:

RELAY OUTPUT	COMMON CONTACT	NORMALLY CLOSED CONTACT	NORMALLY OPEN CONTACT
1 FORM C	1	9	10
1 FORM C	A	K	L

TABLE 1

Power Supply Input:

The power supply input is connected to pins '8' (+12 VDC) and '3' (circuit common). The 3185E requires a power supply capable of providing 50mA minimum, and regulation of the +12 volt, ±10 %.

CUSTOMER OPTIONS

The Model 3185E is factory set to the following:

- Input Impedance:----- 10 k Ω
- Input:----- Unbalanced
- 5 Minute Restoral:----- Enabled
- 20 minute Reset: ----- Disabled
- Output Relay:----- Latching
- 4 Digit Decode Sequence
- * for Fourth Digit 'ON'
- # for Fourth Digit 'OFF'

Jumpers are used to modify these options. See FIGURE 3.

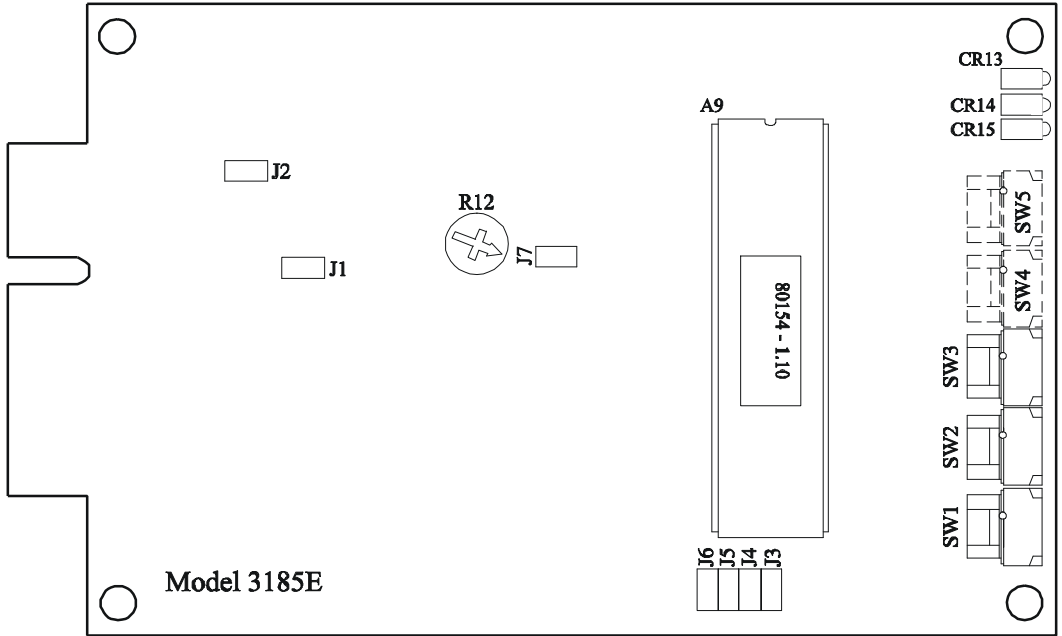

NUMBER OF DIGITS	J6	J5
1	X	X
2	X	O
3	O	X
4	O	O

RELAY OUTPUT MODE	J3	J4
LATCHING	O	O
MOMENTARY	X	O
ALTERNATE	O	X
20 MINUTE LATCH	X	X

X = JUMPER INSTALLED

O = JUMPER REMOVED

R12 = INPUT SIGNAL LEVEL RANGE ADJUSTMENT

	JUMPER	OPEN	SHORTED
INPUT IMPEDANCE	J2	10k Ω [■]	600 Ω
INPUT TERMINATION	J1	BALANCED	UNBALANCED [■]
5 MINUTE RESTORAL	J7	ENABLED [■]	DISABLED
20 MINUTE RESET	J3, J4	DISABLED [■]	ENABLED

[■] = FACTORY SETTING

FIGURE 3
Jumper Locations

Input Impedance:

Input impedance may be either 10 k Ω or 600 Ω . The **J2** jumper determines the input impedance of the 3185E. Install a jumper at position **J2** to terminate the audio input in 600 Ω . Consult FIGURE 3 for the **J2** jumper location.

Input Balanced/Unbalanced:

The input may be selected to be balanced or unbalanced. The **J1** jumper determines whether the input is balanced or unbalanced. Removing the short from **J1** will make the input balanced. Consult FIGURE 3 for the **J1** jumper location.

5 Minute Restoral:

The 3185E may be selected to restore the output status for a power interruption of less than five minutes. The 3185E is factory set to enable this restoral. The **J7** jumper is open. To disable the five minute restoral install a jumper on **J7**. Consult FIGURE 3 for **J7** location.

20 Minute Reset:

A 20-minute reset is provided to reset the output relay 20 minutes after the 'ON' code was received or the 'Set' input was momentarily connected to circuit common. This option is factory set disabled. To enable the option install jumpers on **J3** and **J4**. Consult FIGURE 3 page 7 for the locations of **J3** and **J4**.

Output Relay:

The output relay on the 3185E may be set in three different modes of operation; *latching*, *momentary* or *alternate action* (toggling). The 3185E is factory set to latching.

Being set at *latching* means the output relay will energize when the pre-programmed 'ON' code is received or the 'Set' input is momentarily connected to circuit common. The output relay will remain energized until the preprogrammed 'OFF' code is received or the 'Reset' input is momentarily connected to circuit common.

When the output relay is programmed to operate in the *momentary* mode, it will energize for the duration that the last valid digit is present. In the momentary mode the 3185E will not respond to its pre-programmed 'OFF' code.

Alternate action programs the relay for latching (toggling) relay output. In this mode the output relay energizes and de-energizes with the same pre-programmed 'ON' code sequence.

10 Second Pulse:

If both 'Set' and 'Reset' are low and the relay mode is 'momentary', then when a valid 'ON' sequence of digits is received, the relay is turned on for 10 seconds then 'OFF' – even if the last tone is still present. The decoder will ignore all tones and 'Set' and 'Reset' activities during the 10-second period. Applies only to firmware version 80154-1.10 and later.

The programming of jumpers for the output relay is shown below. Consult FIGURE 3 page 7 for the 'J3' jumper and the 'J4' jumper location.

RELAY OUTPUT MODE	JUMPER	
	J3	J4
LATCHING	O	O
MOMENTARY	X	O
ALTERNATE	O	X
20 MINUTE RESET	X	X

TABLE 2

X = JUMPER INSTALLED

O = JUMPER REMOVED

Number of Digits to Decode:

The 3185E is factory set to decode a 4-digit 'ON' code sequence and a 4-digit 'OFF' code sequence. The first three digits of the code sequence are the same for both 'ON' and 'OFF'. The fourth digit for the 'ON' code sequence is factory set to '*', and the fourth digit for the 'OFF' code sequence is factory set to '#'. The number of digits to decode is determined by jumpers 'J6' and 'J5'. Consult FIGURE 3 page 7 for the location of 'J6' and 'J5'.

The programming of jumpers for the number of digits to decode is shown below:

NUMBER OF DIGITS	JUMPER	
	J6	J5
1	X	X
2	X	O
3	O	X
4	O	O

TABLE 3

X = JUMPER INSTALLED

O = JUMPER REMOVED

Fourth Digit ON/OFF:

The fourth digit of the 'ON' code sequence and the fourth digit of the 'OFF' code sequence are factory set at '*' and '#' respectively. To enable user selection of the fourth digits, it is necessary to remove resistor 'R8' and install two additional selection switches, S4 and S5, plus IC A3. When ordering the switches, please use Monroe Electronics part number '9200002' for each of the two switches and part number '9120375' for the IC required.

Consult the PC board layout (3185E/22) for the location of the parts to be removed and inserted.

CODE SELECTION

The hexadecimal rotary switches on the front edge of the 3185E determine each digit in the code sequence. 0 through D select the corresponding DTMF digit to be decoded. The letter 'E' on the rotary switch represents the '*' DTMF digit and the letter 'F' on the rotary switch represents the '#' DTMF digit.

As stated before, the 3185E is factory set to decode a 4-digit 'ON' code sequence and a 4-digit 'OFF' code sequence. The first three digits of the code sequence are the same for 'ON' and 'OFF' commands. The fourth digit for the 'ON' code sequence is factory set to '*', and the fourth digit for the 'OFF' code sequence is factory set to '#'.

It is not necessary to power down the 3185E when you are programming the code sequence. The 3185E program will read the switch settings each time a code sequence is received.

Consult FIGURE 1 on page 4 for location of switches and their designations.

OPERATION

When the 3185E is connected to a DC power source, the Power/Valid Digit LED CR14 on the front edge of the PC board will be illuminated. This LED indicator will continue to illuminate until a valid DTMF digit is detected or DC power is removed from the board.

The Valid Sequence LED CR15 will illuminate upon the decoding of a correct DTMF code tone pair in the proper sequence. Upon the fourth correct digit, the output relay activates and the Relay Output LED CR13 illuminates.

During the reception of valid DTMF tone pairs in a sequence the 3185E will — after decoding a valid code number — wait for the next valid code in the sequence. If the time between digits is more than 3 seconds, the 3185E will reset and require that the sequence be sent completely again.

Operating With a 4-Digit Code:

When a 4-digit code sequence is selected on the 3185E the switch program will be as follows:

SWITCH 1 = first digit of the code sequence for both 'ON' and 'OFF'.

SWITCH 2 = second digit of the code sequence for both 'ON' and 'OFF'.

SWITCH 3 = third digit of the code sequence for both 'ON' and 'OFF'.

SWITCH 4 = fourth digit of the code sequence for 'ON' (preset to '*' if switch not installed).

SWITCH 5 = fourth digit of the code sequence for 'OFF' (preset to '#' if switch not installed).

If the 3185E is programmed for momentary relay output or alternating relay action SWITCH 5 is not used for programming.

Operating With a 3-Digit Code:

When a 3-digit code sequence is selected on the 3185E the switch program will be as follows:

SWITCH 1 = first digit of code sequence for both 'ON' and 'OFF'.

SWITCH 2 = second digit of code sequence for both 'ON' and 'OFF'.

SWITCH 3 = third digit of code sequence for 'ON'.

SWITCH 4 = third digit of code sequence for 'OFF' (preset to '*' if switch not installed).

If the 3185E is programmed for momentary relay output or alternating relay action SWITCH 4 is not used for programming.

Operating With a 2-Digit Code:

When a 2-digit code sequence is selected on the 3185E the switch program will be as follows:

SWITCH 1 = first digit of code sequence for both 'ON' and 'OFF'.

SWITCH 2 = second digit of code sequence for 'ON'.

SWITCH 3 = second digit for code sequence for 'OFF'.

If the 3185E is programmed for momentary relay output or alternating relay action SWITCH 3 is not used for programming.

Operating With a 1-Digit Code:

When a 1-digit code sequence is programmed into the 3185E the switch program is as follows:

SWITCH 1 = first digit of code sequence for 'ON'.

SWITCH 2 = first digit of code sequence for 'OFF'.

If the 3185E is programmed for momentary relay output or alternating relay action SWITCH 2 is not used for programming.

ADJUSTMENT

Potentiometer **R12** permits the user to adjust the level of the received DTMF tones. This adjustment would be made when the received audio levels are too low or too high to permit reliable decoding. Setting **R12** fully counterclockwise will provide -10 dBmV of gain. Setting **R12** fully clockwise will provide +10 dBmV of gain.

Consult FIGURE 3 on page 7 for the location of potentiometer **R12**.